**MDKUBE15-240-KGT/10-F-2SPU-WN2-N** [↗](#)

Módulo lineal

Tandem actuators with four-row linear recirculating bearing and guideway assembly, monorail guidance system and ball screw drive. With second, non-driven carriage, double nut, single spindle support and fixing slots in carriage

Información técnica

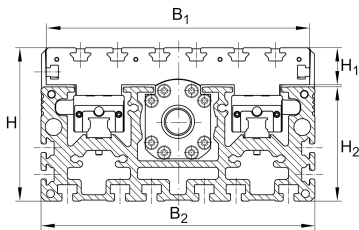

Variante de su producto actual

Size code	15	
Length of carriage	240	240 mm
Drive type	KGT	Ball screw drive
Spindle pitch	10	10 mm
Spindle nut design	F	Flange nut
Additional carriage	WN2	Second, non-driven carriage
Spindle support	2SPU	Double spindle support
Attachment to the carriage	N	T-Slots

Medidas principales y datos de rendimiento

L	240 mm	Length of Carriage
H	105 mm	Total Height
B 2	180 mm	Total Width

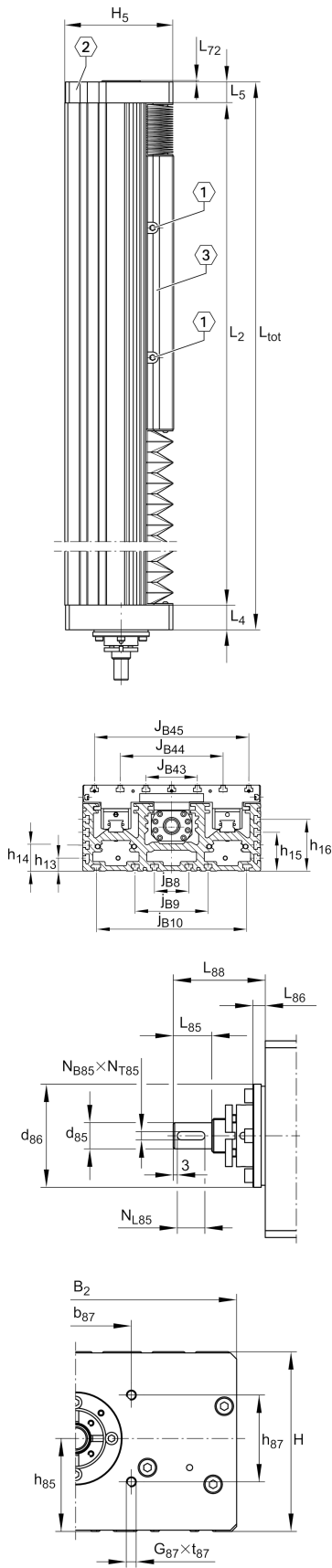

Medidas de montaje

B 1	176 mm	Width of Carriage
b 87	68 mm	
d 85	13 mm	
Tol d 85	h6	Tolerance
d 86	60 mm	
Tol d 86	h7	Tolerance
G 87	M6	Thread
h 13	25 mm	
h 14	45 mm	
h 85	60,5 mm	
h 87	46 mm	
J B43	80 mm	
J B44	130 mm	
j B8	70 mm	
j B9	140 mm	
L 2 max	5.850 mm	Maximum length of Support Rail
L 85	23 mm	
L 86	8 mm	
L 88	42 mm	
N B43	14 mm	
N B85	5 mm	Tolerance P9
N L43	20 mm	
N L85	18 mm	Length of Keyway
N T85	3,5 mm	Depth of Keyway
t 87	15 mm	Depth of Thread



Medidas

Dimension	Value	Description
B_5	179 mm	Width of End Plates
F_{BL}	1,15	Effective length factor of bellow
H_1	29,3 mm	Height of Carriage
H_2	74,5 mm	Width of Support Rail
H_5	103,5 mm	
L_4	28 mm	
L_5	28 mm	
l_{41}	20 mm	
l_{42}	26 mm	
$L_{x1 \text{ min}}$	20 mm	Minimum distance between the Carriages
S_{41}	10 mm	

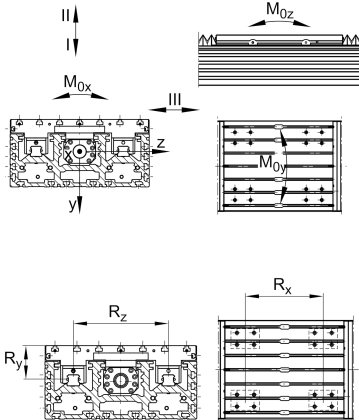

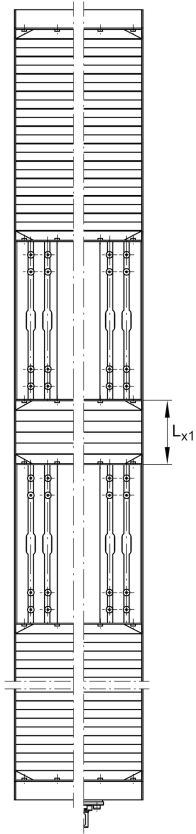
**Datos técnicos**

R_x	174 mm	
R_y	56,5 mm	
R_z	104 mm	
S	10 mm	Safety Distance
m_{LAW}	4,61 kg	Mass of Carriage
m_3	4,2 kg	Mass of additional Carriage
v_{max}	0,5 m/s	Maximum Speed
a_{max}	20 m/s ²	Maximum Acceleration
IC	19.000 N	Load direction I: compressive load
I C ₀	58.000 N	Load direction I: compressive load
II C	19.000 N	Load direction II: tensile load
II C ₀	58.000 N	Load direction II: tensile load
III C	19.000 N	Load direction III: lateral load
III C ₀	58.000 N	Load direction III: lateral load
$M_{0x\ per}$	2.700 Nm	Max. permissible static moment per Carriage
$M_{0y\ per}$	2.950 Nm	Max. permissible static moment per Carriage
$M_{0z\ per}$	3.450 Nm	Max. permissible static moment per Carriage
I_y	1.636 cm ⁴	Geometrical moments of inertia of Support Rail
I_z	200 cm ⁴	Geometrical moments of inertia of Support Rail
$C_{a\ MU}$	12.700 N	Load capacity spindle nut dyn
$C_{0a\ MU}$	22.100 N	Load capacity spindle nut stat
$C_{a\ L}$	17.900 N	Load capacity fixed Spindle bearing dyn
$C_{0a\ L}$	28.000 N	Load capacity fixed Spindle bearing stat
d_0	20 mm	Spindle Diameter
P	10 mm	Spindle Pitch
I_s	0,846 kg*cm ²	Mass moment of inertia of threaded Spindle
2SPU	ja	Double Spindle Support
WN2	Ja	Second, non-driven Carriage



Ver detalles del producto en Medias

11.11.2025, 18:02:37 UTC

SCHAEFFLER

Información adicional

ZKLF1560-2RS-PE Rolling Bearings

F Drive System

4xKWVE15-B-H Carriage