

## MDKUSE25-365-KGT/5-F-2SPU-WN2-N [↗](#)

### Módulo lineal

Tandem actuators with six-row linear recirculating bearing and guideway assembly, monorail guidance system and ball screw drive. With second, non-driven carriage, single nut, double spindle support and fixing slots in carriage

## Información técnica



### Variante de su producto actual

Size code	25	
Length of carriage	365	365 mm
Drive type	KGT	Ball screw drive
Spindle pitch	05	5 mm
Spindle nut design	F	Flange nut
Additional carriage	WN2	Second, non-driven carriage
Spindle support	2SPU	Double spindle support
Attachment to the carriage	N	T-Slots

### Medidas principales y datos de rendimiento

L	365 mm	Length of Carriage
H	145 mm	Total Height
B 2	260 mm	Total Width
≈m	67,4 kg/m	Peso

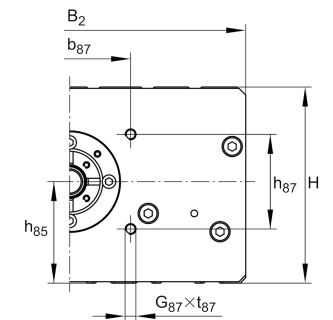

**Medidas de montaje**

B 1	250 mm	Width of Carriage
b 87	90 mm	
d 85	19 mm	
Tol d 85	h6	Tolerance
d 86	75 mm	
Tol d 86	h7	Tolerance
G 87	M8	Thread
h 13	25 mm	
h 14	50 mm	
h 85	75 mm	
h 87	70 mm	
J B43	35 mm	
J B44	115 mm	
J B45	185 mm	
j B8	50 mm	
j B9	110 mm	
j B10	210 mm	
L 2 max	5.850 mm	Maximum length of Support Rail
L 85	28 mm	
L 86	9 mm	
L 88	67 mm	
N B43	14 mm	
N B85	6 mm	Tolerance P9
N L43	20 mm	
N L85	20 mm	Length of Keyway
N T85	3,5 mm	Depth of Keyway
t 87	20 mm	Depth of Thread



### Medidas

$B_5$	259 mm	Width of End Plates
$F_{BL}$	1,18	Effective length factor of bellow
$H_1$	35 mm	Height of Carriage
$H_2$	108 mm	Width of Support Rail
$H_5$	144 mm	
$L_4$	33 mm	
$L_5$	28 mm	
$L_{72}$	2 mm	
$l_{41}$	30 mm	
$l_{42}$	35 mm	
$L_{x1 \text{ min}}$	20 mm	Minimum distance between the Carriages
$S_{41}$	13 mm	

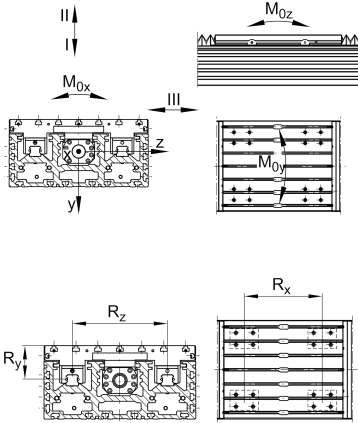

**Datos técnicos**

$R_x$	270 mm	
$R_y$	69,3 mm	
$R_z$	150 mm	
S	5 mm	Safety Distance
$m_{LAW}$	12,84 kg	Mass of Carriage
$m_3$	11,28 kg	Mass of additional Carriage
$v_{max}$	0,215 m/s	Maximum Speed
$a_{max}$	20 m/s <sup>2</sup>	Maximum Acceleration
IC	100.200 N	Load direction I: compressive load
I C <sub>0</sub>	324.000 N	Load direction I: compressive load
II C	68.600 N	Load direction II: tensile load
II C <sub>0</sub>	180.000 N	Load direction II: tensile load
III C	73.800 N	Load direction III: lateral load
III C <sub>0</sub>	188.000 N	Load direction III: lateral load
$M_{0x\ per}$	13.500 Nm	Max. permissible static moment per Carriage
$M_{0y\ per}$	16.200 Nm	Max. permissible static moment per Carriage
$M_{0z\ per}$	15.500 Nm	Max. permissible static moment per Carriage
$I_y$	7.069 cm <sup>4</sup>	Geometrical moments of inertia of Support Rail
$I_z$	899 cm <sup>4</sup>	Geometrical moments of inertia of Support Rail
$C_{a\ MU}$	21.500 N	Load capacity spindle nut dyn
$C_{0a\ MU}$	49.300 N	Load capacity spindle nut stat
$C_{a\ L}$	27.500 N	Load capacity fixed Spindle bearing dyn
$C_{0a\ L}$	55.000 N	Load capacity fixed Spindle bearing stat
$d_0$	32 mm	Spindle Diameter
P	5 mm	Spindle Pitch
$I_s$	6,43 kg*cm <sup>2</sup>	Mass moment of inertia of threaded Spindle
2SPU	ja	Double Spindle Support
WN2	ja	Second, non-driven Carriage



Ver detalles del producto en Medias

11.11.2025, 17:59:57 UTC

SCHAEFFLER

### Información adicional

---

ZKLF2575-2RS-PE Rolling Bearings

F Drive System

4x KWSE25-H Carriage