**MDKUSE25-365-KGT/20-FM-WN2-N** [↗](#)

## Módulo lineal

Tandem actuators with six-row linear recirculating bearing and guideway assembly, monorail guidance system and ball screw drive. With second, non-driven carriage, double nut and fixing slots in carriage

## Información técnica



## Variante de su producto actual

Size code	25	
Length of carriage	365	365 mm
Drive type	KGT	Ball screw drive
Spindle pitch	20	20 mm
Spindle nut design	FM	Flange nut & cylinder nut
Additional carriage	WN2	Second, non-driven carriage
Spindle support	/	None
Attachment to the carriage	N	T-Slots

## Medidas principales y datos de rendimiento

L	365 mm	Length of Carriage
H	145 mm	Total Height
B 2	260 mm	Total Width
≈m	67,4 kg/m	Peso

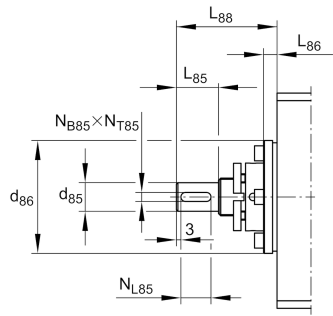

**Medidas de montaje**

B 1	250 mm	Width of Carriage
b 87	90 mm	
d 85	19 mm	
Tol d 85	h6	Tolerance
d 86	75 mm	
Tol d 86	h7	Tolerance
G 87	M8	Thread
h 13	25 mm	
h 14	50 mm	
h 85	75 mm	
h 87	70 mm	
J B43	35 mm	
J B44	115 mm	
J B45	185 mm	
j B8	50 mm	
j B9	110 mm	
j B10	210 mm	
L 2 max	5.850 mm	Maximum length of Support Rail
L 85	28 mm	
L 86	9 mm	
L 88	67 mm	
N B43	14 mm	
N B85	6 mm	Tolerance P9
N L43	20 mm	
N L85	20 mm	Length of Keyway
N T85	3,5 mm	Depth of Keyway
t 87	20 mm	Depth of Thread



### Medidas

$B_5$	259 mm	Width of End Plates
$F_{BL}$	1,18	Effective length factor of bellow
$H_1$	35 mm	Height of Carriage
$H_2$	108 mm	Width of Support Rail
$H_5$	144 mm	
$L_4$	33 mm	
$L_5$	28 mm	
$L_{72}$	2 mm	
$l_{41}$	30 mm	
$l_{42}$	35 mm	
$L_{x1 \text{ min}}$	20 mm	Minimum distance between the Carriages
$S_{41}$	13 mm	

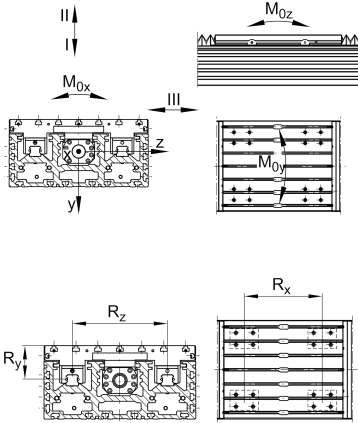

**Datos técnicos**

$R_x$	270 mm	
$R_y$	69,3 mm	
$R_z$	150 mm	
S	20 mm	Safety Distance
$m_{LAW}$	12,84 kg	Mass of Carriage
$m_3$	11,28 kg	Mass of additional Carriage
$v_{max}$	0,86 m/s	Maximum Speed
$a_{max}$	10 m/s <sup>2</sup>	Maximum Acceleration
IC	100.200 N	Load direction I: compressive load
I C <sub>0</sub>	324.000 N	Load direction I: compressive load
II C	68.600 N	Load direction II: tensile load
II C <sub>0</sub>	180.000 N	Load direction II: tensile load
III C	73.800 N	Load direction III: lateral load
III C <sub>0</sub>	188.000 N	Load direction III: lateral load
$M_{0x\ per}$	13.500 Nm	Max. permissible static moment per Carriage
$M_{0y\ per}$	16.200 Nm	Max. permissible static moment per Carriage
$M_{0z\ per}$	15.500 Nm	Max. permissible static moment per Carriage
$I_y$	7.069 cm <sup>4</sup>	Geometrical moments of inertia of Support Rail
$I_z$	899 cm <sup>4</sup>	Geometrical moments of inertia of Support Rail
$C_{a\ MU}$	29.700 N	Load capacity spindle nut dyn
$C_{0a\ MU}$	59.800 N	Load capacity spindle nut stat
$C_{a\ L}$	27.500 N	Load capacity fixed Spindle bearing dyn
$C_{0a\ L}$	55.000 N	Load capacity fixed Spindle bearing stat
$d_0$	32 mm	Spindle Diameter
P	20 mm	Spindle Pitch
$I_s$	6,43 kg*cm <sup>2</sup>	Mass moment of inertia of threaded Spindle
WN2	ja	Second, non-driven Carriage



### Información adicional

---

ZKLF2575-2RS-PE	Rolling Bearings
-----------------	------------------

FM	Drive System
----	--------------

4x KWSE25-H	Carriage
-------------	----------