

# Habasit® Cleandrive Sprocket Series CD40

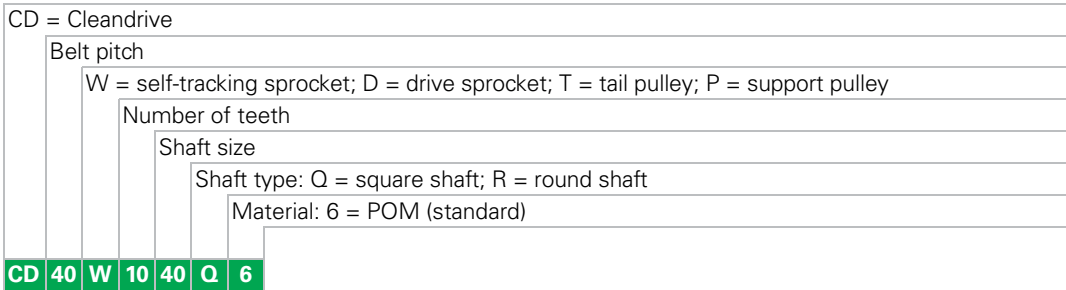

## Sprocket availability

Type	Number of teeth	Diam. of pitch $\varnothing d_p$		$A_1$		Hub width $B_L$		Square bore Q		Standard material
		mm	inch	mm	inch	mm	inch	mm	inch	
D-C3	16	203.2	8.0	93.0	3.66	160	6.30	40	1.5	POM
D-C3	12	152.4	6.0	67.6	2.66	160	6.30	40	1.5	POM
D-C3	10	127.0	5.0	54.9	2.16	160	6.30	40	1.5	POM
D-C3	8	101.6	4.0	42.2	1.66	160	6.30	40	1.5	POM
D-C3	6	76.4	3.0	29.5	1.16	160	6.30	25	1	POM
W-C3	16	203.2	8.0	93.0	3.66	160	6.30	40	1.5	POM
W-C3	12	152.4	6.0	67.6	2.66	160	6.30	40	1.5	POM
W-C3	10	127.0	5.0	54.9	2.16	160	6.30	40	1.5	POM
W-C3	8	101.6	4.0	42.2	1.66	160	6.30	40	1.5	POM
W-C3	6	76.4	3.0	29.5	1.16	160	6.30	25	1	POM

\*-C3: Machined sprockets

Other sprocket and hub sizes on request.

**Key ways** for round bore shape follow European standards for metric sizes and US standards for imperial sizes. For detailed dimensions see table in the Design Guide.

**Other materials** available on request.

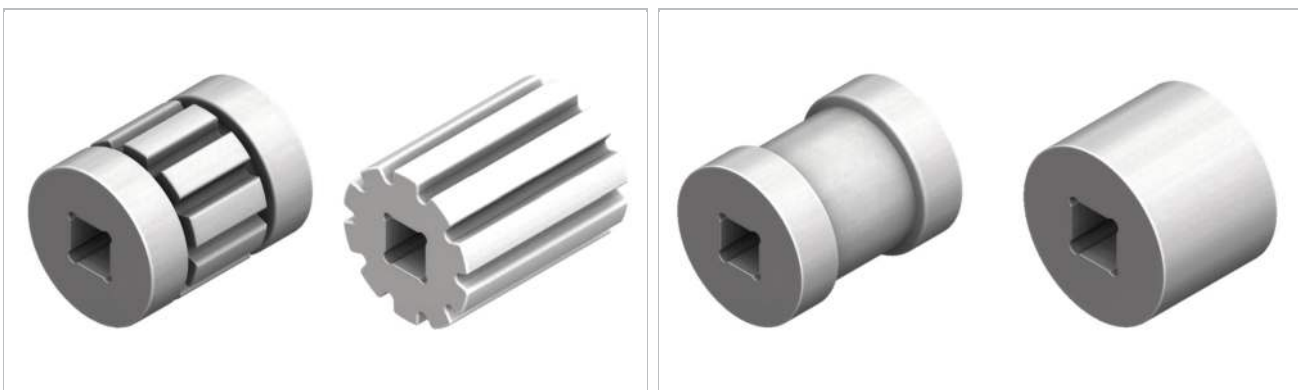

**W** = self-tracking sprocket (left) and **D** = drive sprocket (right)

**T** = tail pulley (left) and **P** = support pulley (right)

## Sprocket arrangement

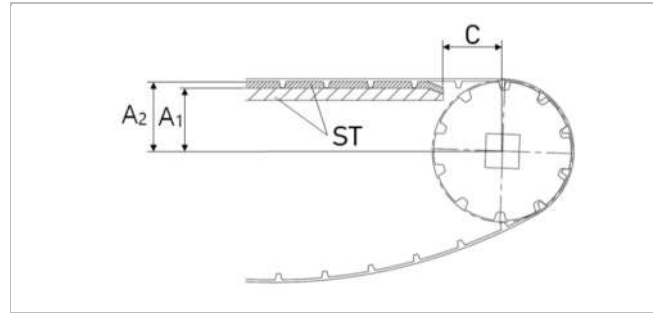
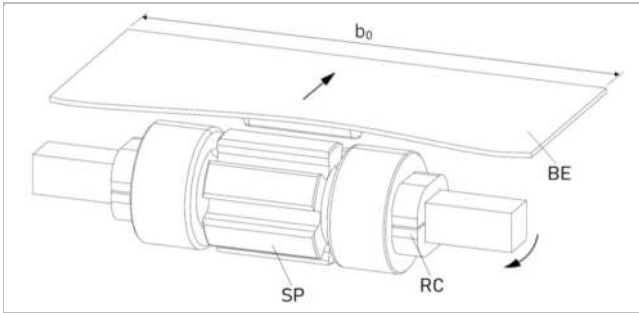

**BE** Belt  
**RC** Retainer  
**SP** Sprocket  
**b<sub>0</sub>** belt width

The distance **C** between the sprocket axis and the slider support **ST** is minimal 53 mm (2.1").

### Wearstrips

Between driving shaft and idling sprockets or rollers the belt is carried by a slider support furnished with longitudinal wear strips from UHMW Polyethylene or other suitable material.

If the maximal load is concentrated in the middle of the belt we recommend supporting the lugs by an additional wear strip. This avoids localized belt deformation and excessive belt abrasion from wear strips adjacent to the lugs. It is always recommended to support the lug area on the return way.

## Number of sprockets and wearstrips

To ensure the right amount of belt support on the driving shaft, use minimum 70% of the belt width for sprockets and support rollers. For the idler shaft is just 50% of the total support length.

The table below shows the number of sprockets including distances for typical belt widths  $b_0$ . To calculate the adjusted belt tensile force contact your Habasit representative.

Belt width $b_0$ [mm] / [inch]	Number of lug rows and sprockets		Minimum number of wear strips	
			Carry way	Return way
150 / 6	1		2	2
200 / 8	1		4	2
250 / 10	1		4	2
300 / 12	1		4	2
350 / 14	1		4	2
400 / 16	1		4	2
450 / 18	1		4	2
500 / 20	1		4	3
550 / 22	1		6	3
609 / 24	1		6	3
650 / 26	1		6	4
700 / 28	1*	2	6	4
750 / 30	1*	2	6	4
800 / 32	1*	2	8	4
850 / 34	1*	2	8	5
900 / 36	1*	2	8	5
950 / 38	1*	2	9	5
1000 / 40	1*	2	9	5
1100 / 44	1*	2	11	6
1200 / 48		2	11	6
1300 / 52		2	12	6
1400 / 56		2	14	7
1500 / 60		2	14	7
1650 / 64		2	16	8
1750 / 68		2	18	8
1810 / 72		2	18	9

\*possible just from the middle row

For belt widths greater than 685 mm (27"), use no fewer than two lug rows if the admissible tensile force utilized is above 50%.

### Disclaimer

#### Product Application Disclaimer (valid for ALL Habasit products and mentioned on all PDS)

This disclaimer is made by and on behalf of Habasit and its affiliated companies, directors, employees, agents and contractors (hereinafter collectively "HABASIT") with respect to the products referred to herein (the "Products"). SAFETY WARNINGS SHOULD BE READ CAREFULLY AND ANY RECOMMENDED SAFETY PRECAUTIONS BE FOLLOWED STRICTLY! Please refer to the Safety Warnings herein, in the Habasit catalogue as well as installation and operating manuals. All indications / information as to the application, use and performance of the Products are recommendations provided with due diligence and care, but no representations or warranties of any kind are made as to their completeness, accuracy or suitability for a particular purpose. The data provided herein are based on laboratory application with small-scale test equipment, running at standard conditions, and do not necessarily match product performance in industrial use. New knowledge and experience may lead to re-assessments and modifications within a short period of time and without prior notice. EXCEPT AS EXPLICITLY WARRANTED BY HABASIT, WHICH WARRANTIES ARE EXCLUSIVE AND IN LIEU OF ALL OTHER WARRANTIES, EXPRESS OR IMPLIED, THE PRODUCTS ARE PROVIDED "AS IS". HABASIT DISCLAIMS ALL OTHER WARRANTIES, EITHER EXPRESS OR IMPLIED, INCLUDING, BUT NOT LIMITED TO, IMPLIED WARRANTIES OF MERCHANTABILITY, FITNESS FOR A PARTICULAR PURPOSE, NON-INFRINGEMENT, OR ARISING FROM A COURSE OF DEALING, USAGE, OR TRADE PRACTICE, ALL OF WHICH ARE HEREBY EXCLUDED TO THE EXTENT ALLOWED BY APPLICABLE LAW. BECAUSE CONDITIONS OF USE IN INDUSTRIAL APPLICATION ARE OUTSIDE OF HABASIT'S CONTROL, HABASIT DOES NOT ASSUME ANY LIABILITY CONCERNING THE SUITABILITY AND PROCESS ABILITY OF THE PRODUCTS, INCLUDING INDICATIONS ON PROCESS RESULTS AND OUTPUT.