

HabasitLINK® sprockets – 1 3/4" pitch belting CC41, CC42

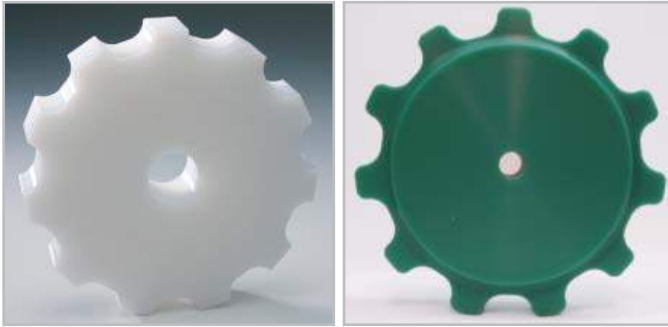

Drive sprocket

Tracking sprocket

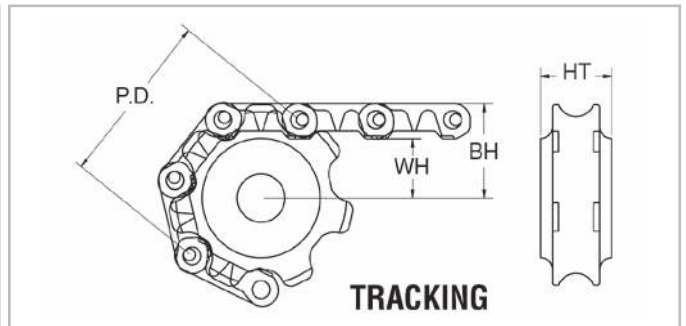
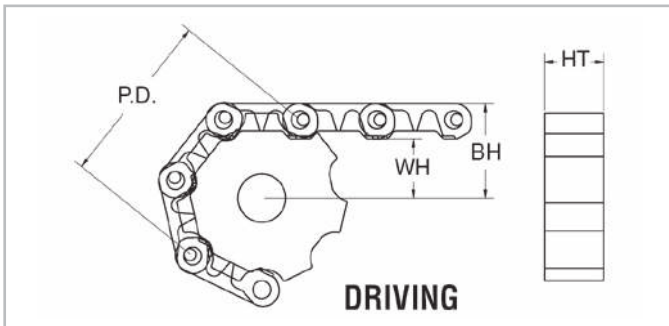

Sprocket part number	Number of teeth	(PD) Nominal pitch diameter		(WH) Shaft center to top of wearstrip		(BH) Shaft center to top of belt		Drive (T) Tooth thickness		Drive (HT) Hub thickness		Tracking (HT) Hub thickness	
		inch	mm	inch	mm	inch	mm	inch	mm	inch	mm	inch	mm
471707	7	4.03	102	1.64	42	2.39	61	1.25	32	1.25	32	1.5	38
471709	9	5.12	130	2.19	56	2.94	75	1.25	32	1.25	32	1.5	38
471711	11	6.21	158	2.73	69	3.48	88	1.25	32	1.25	32	1.5	38
471713	13	7.31	186	3.28	83	4.03	102	1.25	32	1.25	32	1.5	38
471714	14	7.86	200	3.56	90	4.31	109	1.25	32	1.25	32	1.5	38
471717	17	9.52	242	4.39	112	5.14	131	1.25	32	1.25	32	1.5	38
471721	21	11.74	298	5.50	140	6.25	159	1.25	32	1.25	32	1.5	38

Split sprockets and other tooth sizes are available. Standard machined sprocket material is UHMW, Nylon and Urethane are available.

Sprocket part number	Available bore size														
	25 mm	1"	1" sq.	30 mm	1-1/4"	1-7/16"	1-1/2"	1-1/2" sq.	40 mm	40 mm sq.	1-15/16"	50 mm	2"	2-1/2" sq.	
471707	✓	✓	✓	✓	✓	✓	✓	✓	✓	✓	✓	✓	✓	–	
471709	–	✓	✓	✓	✓	✓	✓	✓	✓	✓	✓	✓	✓	✓	
471711	–	✓	✓	✓	✓	✓	✓	✓	✓	✓	✓	✓	✓	✓	
471713	–	✓	✓	✓	✓	✓	✓	✓	✓	✓	✓	✓	✓	✓	
471714	–	✓	✓	✓	✓	✓	✓	✓	✓	✓	✓	✓	✓	✓	
471717	–	–	–	–	✓	✓	✓	✓	✓	✓	✓	✓	✓	✓	
471721	–	–	–	–	✓	✓	✓	✓	✓	✓	✓	✓	✓	✓	

All bore sizes are round bore unless designated square (sq.).