

HabasitLINK® sprockets – 1/2" pitch belting RS511, RS515

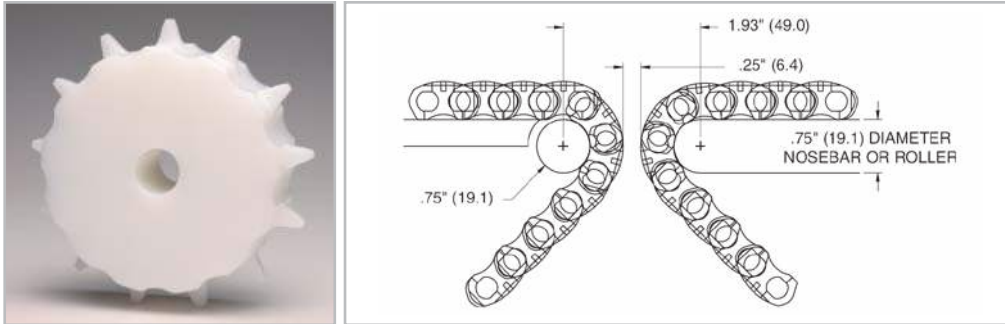

Machined sprocket
Split sprockets and other sizes are available.

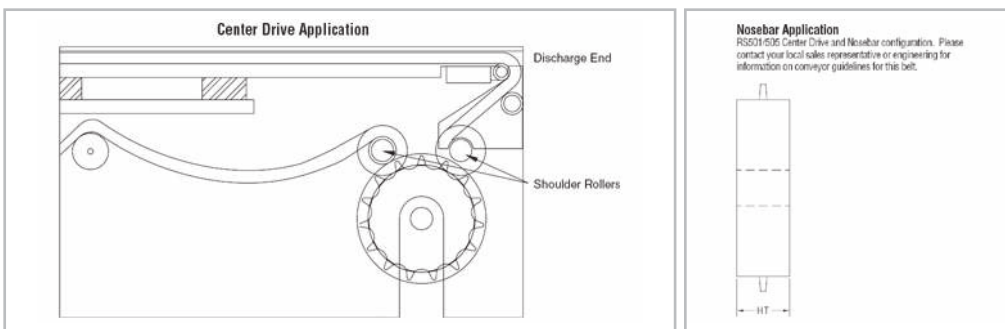

Sprocket part number	Number of teeth	(PD) Nominal pitch diameter		(WH) Shaft center to top of wearstrip		(BH) Shaft center to top of belt		Curved Top (BH) Shaft center to top of belt curve		(HT) Hub thickness	
		inch	mm	inch	mm	inch	mm	inch	mm	inch	mm
070515 L/S	15	5.40	137	0.38	10	0.88	22	0.91	23	1.5	38

Do not use sprockets smaller than 11 tooth, 4.0" (101.6 mm), as drive sprockets. Specify belt material at time of ordering for correct sprocket sizing. Split sprockets and other tooth sizes are available. Standard machined sprocket material is Nylon, UHMW and Urethane are available. Shoulder rollers required at both ends of drive shaft to capture belt for optimum sprocket engagement and belt support at the belt edges where no sprocket path exists.

Sprocket part number	Available bore size															
	1"	1" sq.	30 mm	1-1/4"	1-7/16"	1-1/2"	1-1/2" sq.	40 mm	40 mm sq.	1-15/16"	50 mm	2"	60 mm	60 mm sq.	2-1/2" sq.	
070515 L/S	✓	✓	✓	✓	✓	✓	✓	✓	✓	✓	✓	✓	✓	✓	✓	

M = molded sprocket

All bore sizes are round bore unless designated square (sq.).

Do not use sprockets smaller than 11 tooth, 4.0" (101.6 mm), as drive sprockets. Specify belt material at time of ordering for correct sprocket sizing.