

HabasitLINK®

Installation instructions for belt type M2483 Sphere Top 1”

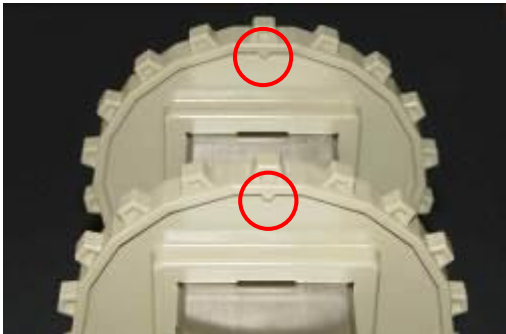

Sprocket alignment on the shafts:

Corresponding teeth axial aligned, check by alignment mark.

If the bore is square and the number of teeth can be divided by 4, there may be no mark.

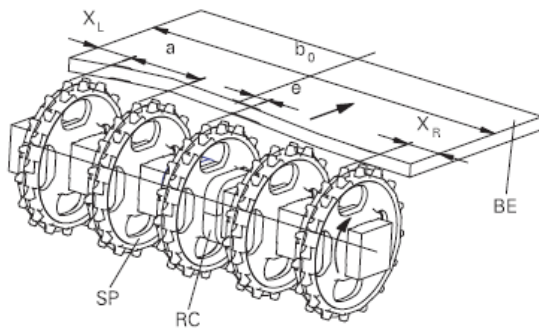

Sprockets Positioning:

Place sprockets between min. and max. spacing (a).

Respect edge distance X_L and X_R .

Offset (e) given by shaft design.

Fix only the center sprocket with a small clearance.

Belt type	Sprocket spacing a		Edge distance	
	minimal mm inch	maximal mm inch	X_L mm inch	X_R mm inch
M2483	25.4 1	127.0 5	25.4 1	25.4 1



Check proper sprocket engagement:

The sprocket teeth must properly engage into the belt openings between the spheres.

Belt reverse side is in contact with the sprocket rim.

If possible avoid sprocket placement at module seams.

Belt joining:

The following belt views are from the belt reverse side.

Note: The stainless-steel floaters holding the sphere in place need to be positioned always on the same side of the spheres, see red arrows. Install belts sections accordingly.

Procedure how to join the belt segments:

1. Belt segments including a plastic floater. Align belt sections in order the steel floaters are on the same side of the spheres.

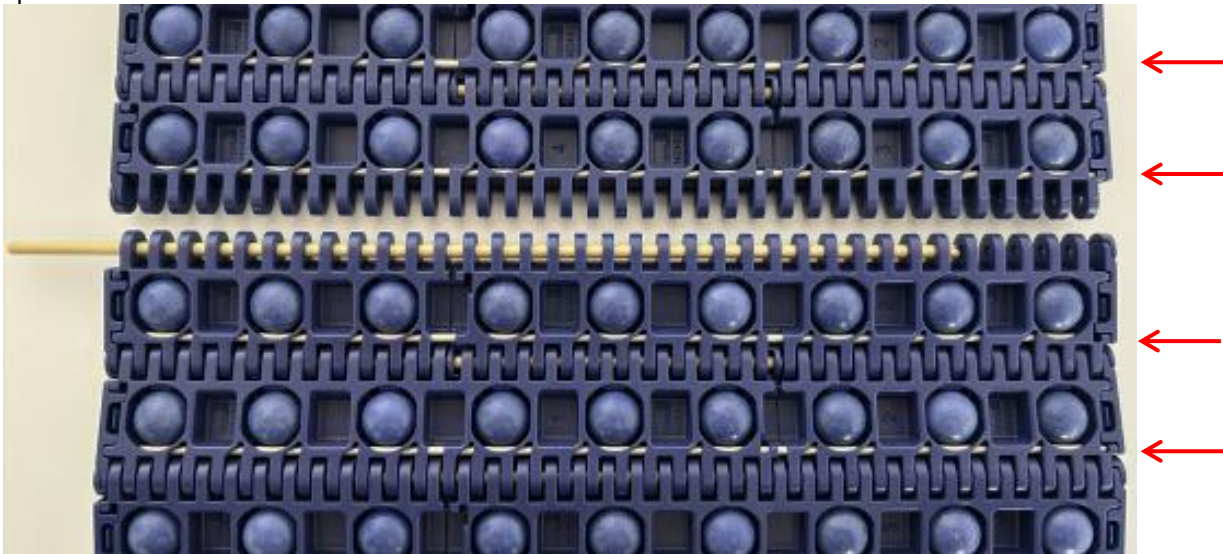

Belt reverse side

2. Take out the plastic floater, diameter 3 mm. This floater is part of the shipment and may be separate.



Belt reverse side

3. Remove edge clip

Press the clip between your thumb and index finger, the lever will slightly bend and allow to pull the clip up and out of the retaining cavity. This needs a little practice. A small screw drive might be helpful. Watch your fingers!



Belt reverse side

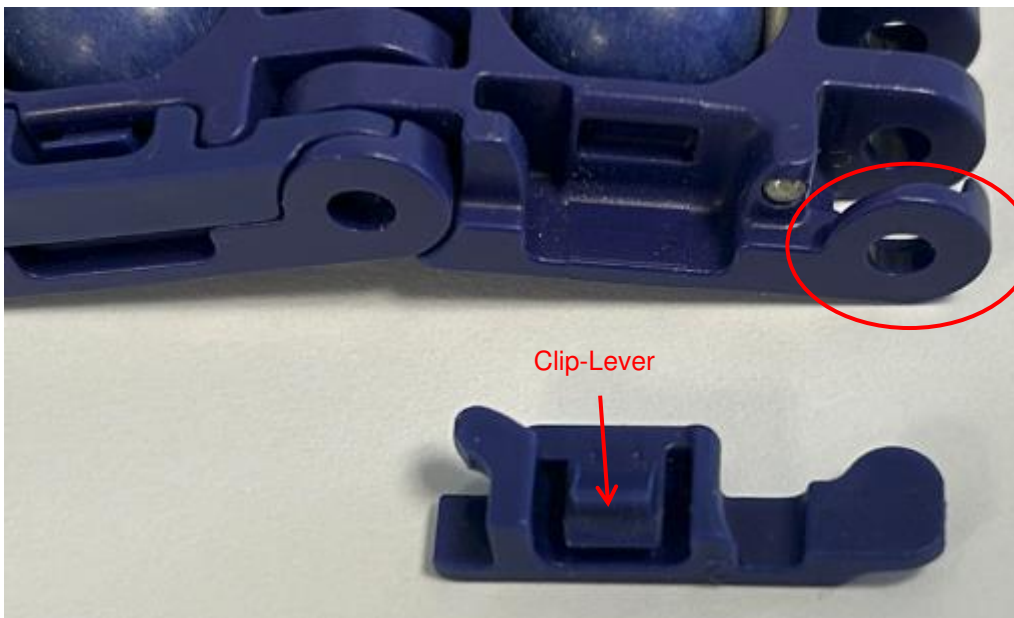

Belt reverse side

4. Align the belt segments and push them together. Insert the plastic floater through the 3 mm hole

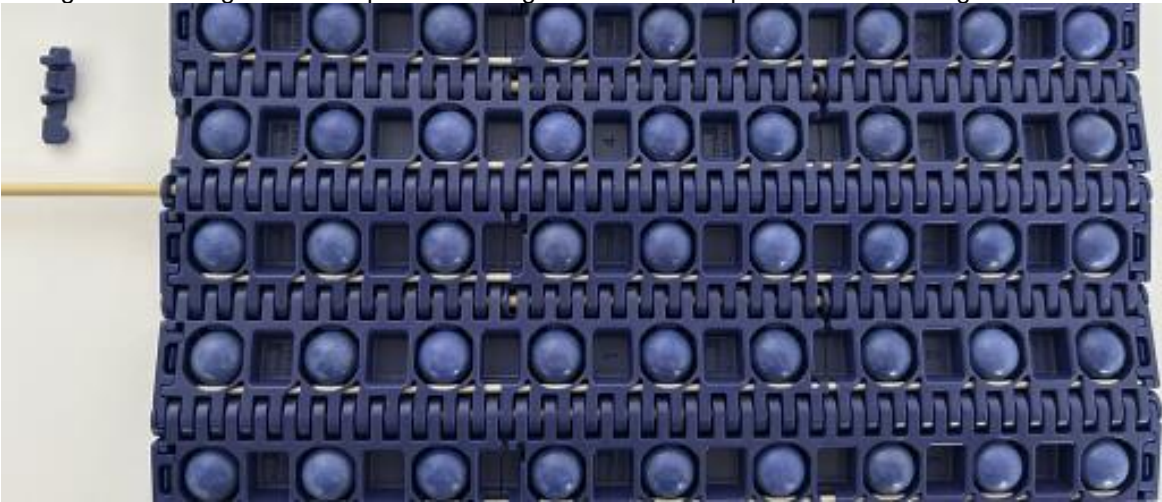

Belt reverse side

5. Insert edge clip until the clip is properly engaged and flush.

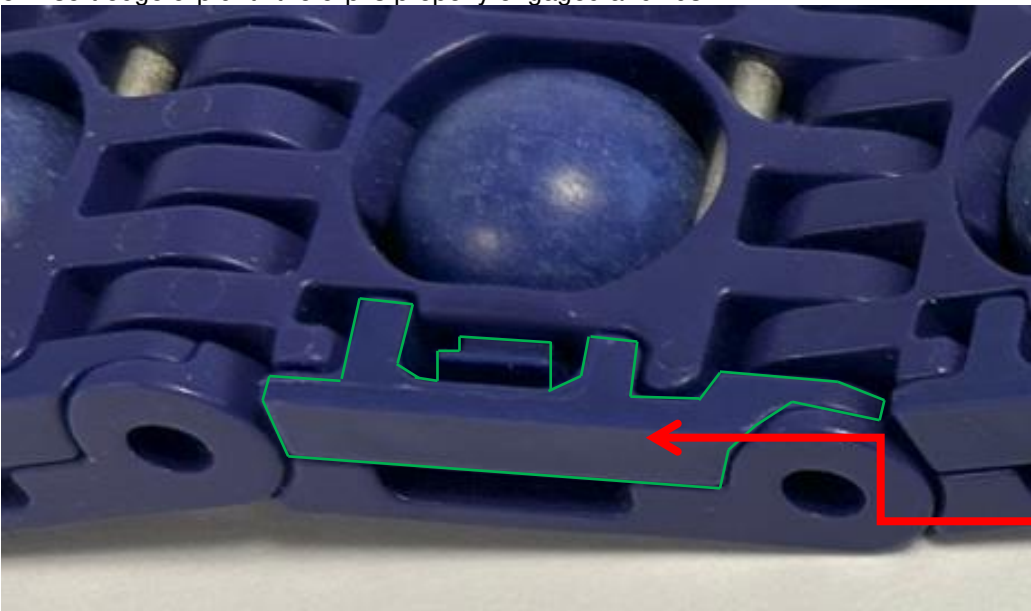

Clips at belt edges only

Belt reverse side

Repeat 1-5 process until the belt is in one piece remaining one final closing. Install the belt on the conveyor and close the belt repeating 1-5 process.

In case the steel floater moved outside a module

Steel floater assembly

The steel floaters are applied to hold the speres in position and sit in the 2 mm diam bore.

In case the steel floater is removed or protruding the 2 mm hole, follow the belt assembly procedure below.

Description:

Edge clip code M2483P0153-N1

Install the clips at belt edge only (no clips in the belt center). The clip does fit to edge A and B.



Module edge design:

Edge A

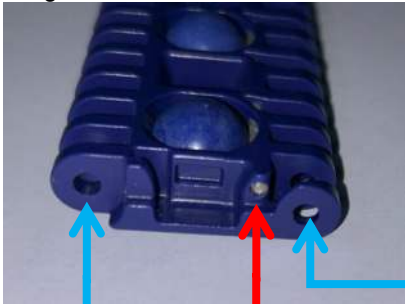

3 mm hole for
plastic rod

2 mm hole for
steel floater

3 mm hole for
plastic rod

Edge B:

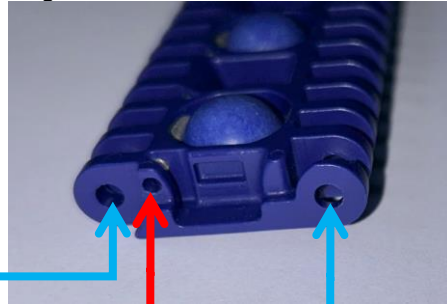

2 mm hole for
steel floater

3 mm hole for
plastic rod

Required floaters:

Plastic floater diameter 3 mm code MGPA3 (rod retaining is cut off)

Steel floater diameter 2 mm code M0FA2



Belt Assembly procedure:

- Consider steel floater hole (diam. 2 mm) must be aligned with all the module in the same row while the clip opening is at the desired belt edge side.
- Bricklay modules showing up the return side. Consider steel floater hole (diam. 2 mm) will be aligned with all the module in the same row.
- Check if the plastic floater length is (actual belt width minus 10 mm) * 0.99 (minus tolerance).
- Insert first the plastic floater in the diam. 3 mm module hole from the edge. Ensure the plastic floaters are approx. 5 mm each edge inside the module.
- Insert spheres into the cavities of the modules.
- Check if the steel floater length is actual belt width minus 5 mm (minus tolerance).
- Insert stainless steel floater in the diam. 2 mm module hole from the edge. Ensure spheres are held back by the steel floater, **therefore lift the modules slightly** in order the spheres are fully in the opening of the module. Check if all spheres are retained by the steel floater.

Belt reverse side: The spheres must be below the steel floater. During steel floater installation lift the modules slightly in order stainless steel floater will easily move above the spheres.



- Close the belt edge by clips:

<p>1. Belt edge B Insert the steel floater in 2 mm bore and push it back approx. to red line. Insert 1. clip.</p> <p>The steel floater is held by the “rear” part of the clip, see green circle.</p>	
<p>2. Belt edge A Push steel floater back to red line. Insert 2. Clip.</p> <p>The steel floater is held by the “front” part of the clip, see orange circle.</p>	

- Check if the clips are fully embedded.

Product liability, application considerations

If the proper selection and application of Habasit products are not recommended by an authorized Habasit sales specialist, the selection and application of Habasit products, including the related area of product safety, are the responsibility of the customer. All indications / information are recommendations and believed to be reliable, but no representations, guarantees, or warranties of any kind are made as to their accuracy or suitability for particular applications. The data provided herein are based on laboratory work with small-scale test equipment, running at standard conditions, and do not necessarily match product performance in industrial use. New knowledge and experiences can lead to modifications and changes within a short time without prior notice.

BECAUSE CONDITIONS OF USE ARE OUTSIDE OF HABASIT'S AND ITS AFFILIATED COMPANIES' CONTROL, WE CANNOT ASSUME ANY LIABILITY CONCERNING THE SUITABILITY AND PROCESS ABILITY OF THE PRODUCTS MENTIONED HEREIN. THIS ALSO APPLIES TO PROCESS RESULTS / OUTPUT / MANUFACTURING GOODS AS WELL AS TO POSSIBLE DEFECTS, DAMAGES, CONSEQUENTIAL DAMAGES, AND FURTHER-REACHING CONSEQUENCES.